

IPG MID-POWER SCANNER

2KW REMOTE SCANNING SOLUTION

Enables Remote Scanning Applications
with QCW or CW IPG Lasers



Suitable Applications

- Welding
- Cutting
- Deep Engraving
- Additive Manufacturing

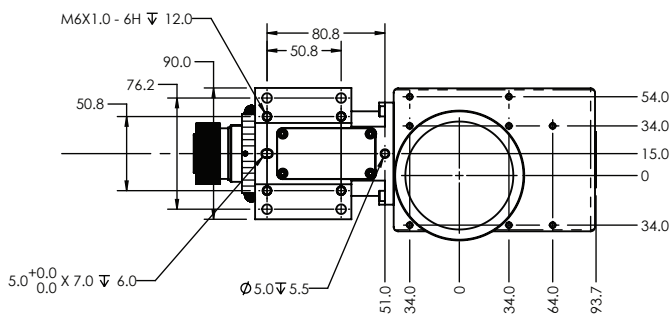
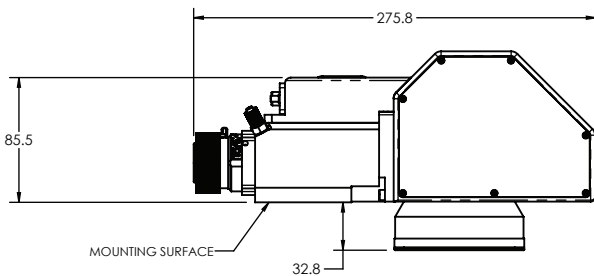
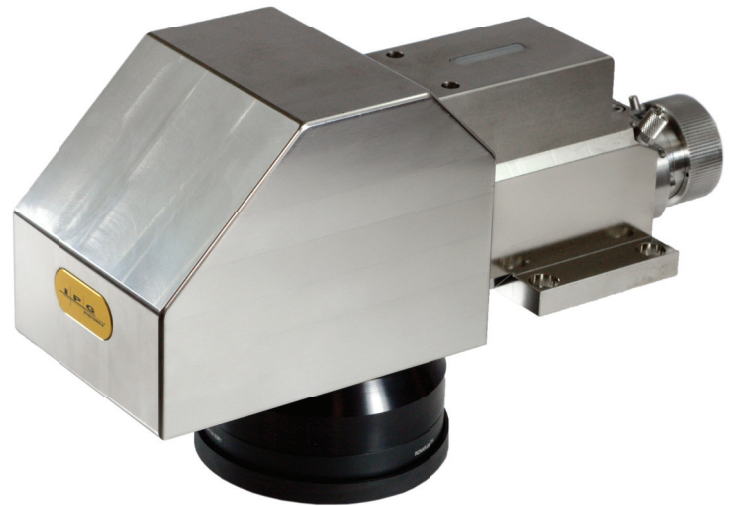

Specifications

Wavelength	1070 - 1080 nm
Max Laser Power	2 kW CW
Mirror Clear Aperature	12 mm
Fiber Adaptor	HLC-8

Dynamic Performance

Tracking Delay	< 0.1 ms
Repeatability (rms)	< 5 urad
Long-term drift	< 1 mrad <small>Over 8 hours (after warm-up)</small>
Communication	XY2-100

Optical Configurations

Collimator FL	50 mm
Focal Length Options	100 mm 160 mm 250 mm

